

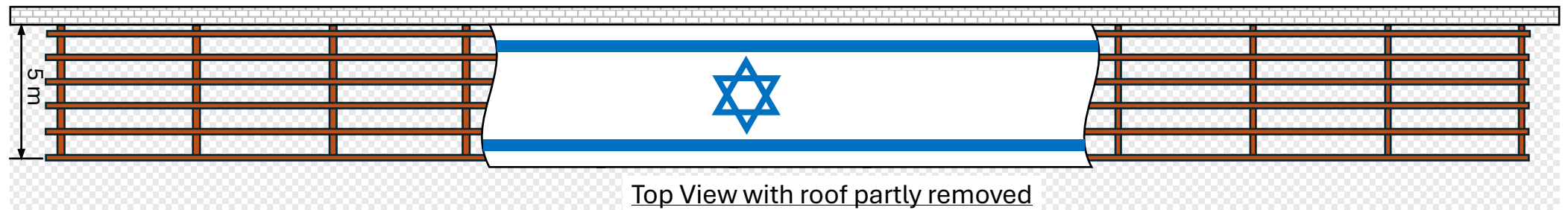

Constructing a temple in three days at the Western Wailing Wall to Honour and Worship Jesus as the Jewish Messiah.

Isaiah 66 ¹Thus says the Lord: “Heaven is my throne, and the earth is my footstool; what is the house that you would build for me, and what is the place of my rest? ²All these things my hand has made, and so all these things came to be, declares the Lord. But this is the one to whom I will look: he who is humble and contrite in spirit and trembles at my word.

John 2 ¹⁹Jesus answered them, “Destroy this temple, and in **three** days I will raise it up.”

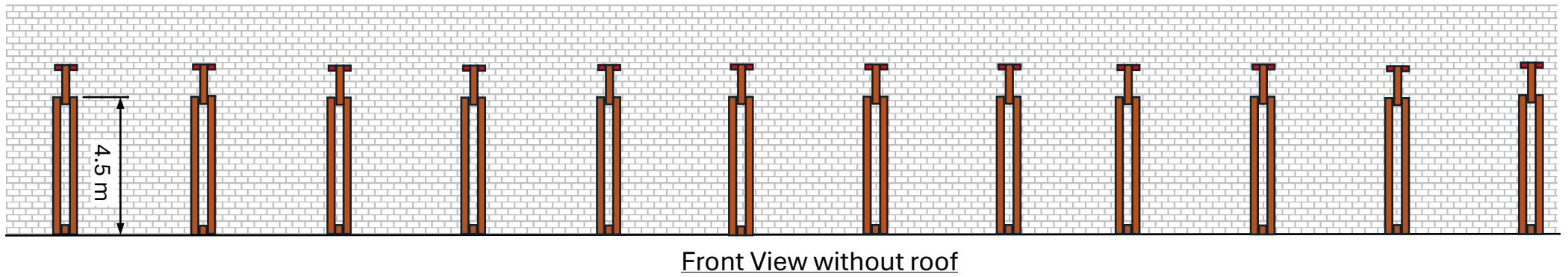
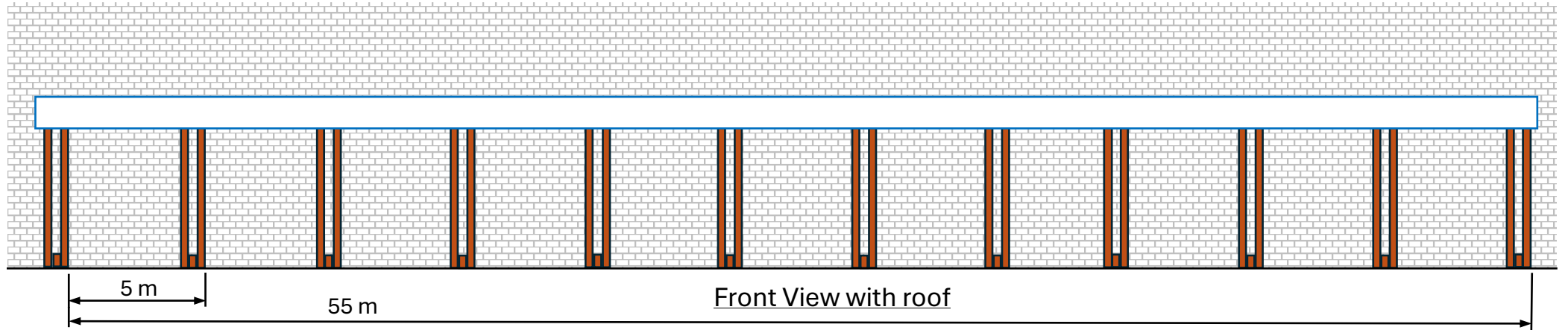

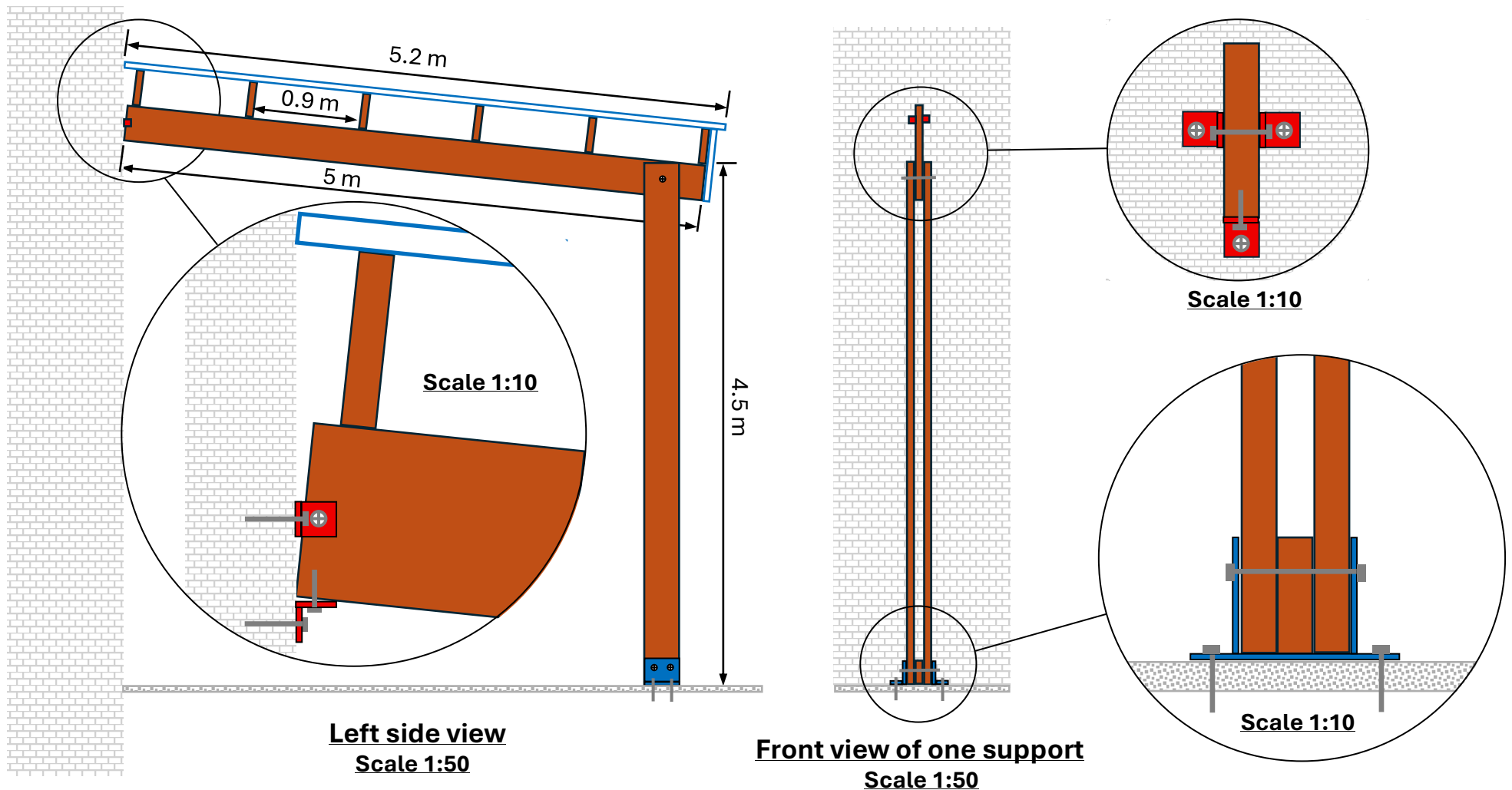

This whole structure represents the Nation of Israel that is **bowing** before Jesus the Son of God. The wall represents Jesus. There are twelve upright pillars with a horizontal roof beam attached to each one. These twelve objects represent the twelve tribes of Israel. Each individual one represents a Jew. The two upright beams represent the two legs of the Jew. The horizontal roof beam with the crossmembers represents the back with the spine of the Jew. The little overhang of the horizontal roof beam to the right of the upright pillar is the bum of the Jew. Where the upright pillar meets the ground is the feet of the Jew. The Jew is wearing blue shoes. The roof is the clothing of the Jew. The three bolts that attaches the roof beam to the wall represents the three nails with which Jesus was crucified. The above two red 90° angle irons are the ears of the Jew, and the one below is the tongue of the Jew. The 90° angle irons are red because Jesus bled on the cross to pay the penalty for our sins. You can however only receive the forgiveness of

your sins from God if you believe this Gospel. Buy praying under this roof a Jew is therefore not only **bowing** before Jesus as **Lord and Messiah** but is also **testifying** that he has **heard** the Gospel of Jesus Christ and that he **believes** it. In other words, he has met the two requirements of the Gospel namely, to **repent** of sin and **trust** in the death and resurrection of Jesus.

Romans 10 ⁹*because, if you confess with your mouth that Jesus is Lord and believe in your heart that God raised him from the dead, you will be saved. ¹⁰For with the heart one believes and is justified, and with the mouth one confesses and is saved.*

On the cross Jesus suffered physical torture to the point of death, as well as severe humiliation and rejection while he completely submitted his will and power to his mission to be a worthy sacrifice for the sins of humanity. The least the Jews of Israel can do for him if they eventually also decide to accept him as their messiah and king is to drill 36 holes into their beloved old historic holy wailing wall to put a roof upon their place of prayer.

According to the Bible a temple for God is simply an official prayer house where his nation can pray to him as a nation. This temple might look cheap, humble and simple to the Jews compared to their old Temple that was destroyed in 70 A.D. by the Romans. But remember Jesus said that he is humble in spirit and his yoke is light. He was born in a stable, laid in a manger and his **New Covenant** message of salvation don't require a complicated system of animal sacrifices, but rather just faith in his finished work on the cross. If you believe the Gospel then Jesus implants you with his Holy Spirit that empowers you to have victory over the power of sin.

Jeremiah 31 ³¹*“Behold, the days are coming, declares the Lord, when I will make a **new covenant** with the house of Israel and the house of Judah, ³²**not like the covenant that I made with their fathers** on the day when I took them by the hand to bring them out of the land of Egypt, my covenant that they broke, though I was their husband, declares the Lord. ³³For this is the covenant that I will make with the house of Israel after those days, declares the Lord: I will put my law within them, and I will write it on their hearts. And I will be their God, and they shall be my people. ³⁴And no longer shall each one teach his neighbor and each his brother, saying, ‘Know the Lord,’ for they shall all know me, from the least of them to the greatest, declares the Lord. For I will forgive their iniquity, and I will remember their sin no more.”*

Each Jew requires 12 bolts to construct (6 bolts at the floor, 1 bolt to connect the upright beams to the horizontal roof beam and 5 bolts at the wall) There are 12 Jewish tribes which gives you 144 bolts in total. The bolts work with 36 red 90° angle irons and 12 blue iron base plates. The structure requires 78 wooden beams of 5-meter length each and 24 wooden beams of 4.5-meter length each as well as 12 similar width wooden spacers of 0.2-meter length at the feet. The roof should be made of corrugated iron. The structure is therefore made exclusively of wood and iron, because Jesus was nailed with iron spikes to a wooden cross. To put up the structure drill the 4 holes into the ground at each base and attach the blue base plates with bolts, which must be fastened with grout to their holes on **day one**. Use quick setting grout that will harden in a day. On **day two** put up the upright pillars and roof beams against the wall with one gut line, spanning the length of the wall close to the wall and another above the pillars, to create a level roof structure. Once this is done mark the holes against the wall with the help of the holes in the red 90° angle irons and drill them inside the wall about 70 mm deep. Then attach the red 90° angle irons to the wall with their bolts that are grouted into their holes. Also fasten the red 90° angle irons to the wooden beams with their bolts. On **day three** the roof must be put up. First the 6 x 11 cross beams and then the roof covering. Three easy steps. Day one. Day two. Day three. Jesus rose from the grave after three days, just as he prophesied he would.

www.naughtyboy.com

More reasons why Jesus is the Lord and the Son of God

In Isaiah 9 below it is prophesied that God will become a man, the Messiah, through birth. Jesus claimed to be the Son of God. That is also why he was crucified. It is far fetched and irrational for any human being to claim he is God, unless he really is. Jesus preached and explained his message in the most beautiful and marvellous ways. Huge crowds followed him everywhere to listen to his words. He was definitely not crazy. He was indeed a **wonderful counselor** like it says in Isaiah 9:6 below. Jesus said that if you do not believe in him on account of his words then believe on account of his deeds. Jesus did many miraculous signs and wonders that proved himself to be God, like healing many people of any type of ailment, walking on water, calming a storm at sea, feeding thousands of people by increasing a little bread and fish, turning water into wine, raising the dead etc. Jesus predicted his death by crucifixion and his resurrection from the dead three days later, many times during his ministry. The fact that he rose from the dead proves that he is God like he claimed during his trail and that his words are true. There were many eyewitnesses that saw the deeds of Jesus. These are the people that formed the early church in Jerusalem. They accepted the New Testament as true, because they were eyewitnesses to the life of Jesus. Jesus appeared to his disciples after he was raised from the grave. They preached his message all over the known world after he was taken up into heaven. None of them altered his story even though they were persecuted to the point of death. Nobody would die for a made-up story that is a lie. The fact that they all preached the same message under pressure without coordination (because they travelled all over the known world) proves they spoke about what they saw and heard from Jesus. The Covenant of Moses was given in the same manner as the New Covenant that was given by Jesus. In both cases many miracles happened that were viewed by the whole nation which affirmed that it was an act of God almighty and a message from him. Any Jew who takes an intellectually honest view at the evidence must admit that Jesus is who he claimed to be.

Isaiah 9

*⁶For to us a **child is born**, to us a son is given; and the government shall be upon his shoulder, and his name shall be called **Wonderful Counselor, Mighty God, Everlasting Father, Prince of Peace**. ⁷Of the increase of his government and of peace there will be no end, on the throne of David and over his kingdom, to establish it and to uphold it with justice and with righteousness from this time forth and forevermore. The zeal of the Lord of hosts will do this.*

Jesus the Wonderful Counselor

Matthew 7 ²⁸And when Jesus finished these sayings, the crowds were astonished at his teaching, ²⁹for he was teaching them as one who had authority, and not as their scribes. **Matthew 13** ⁵³ And when Jesus had finished these parables, he went away from there, ⁵⁴ and coming to his hometown he taught them in their synagogue, so that they were astonished, and said, "Where did this man get this wisdom and these mighty works?" **Matthew 22** ³³And when the crowd heard it, they were astonished at his teaching. **Matthew 22** ⁴⁶ And no one was able to answer him a word, nor from that day did anyone dare to ask him any more questions.

Jesus the Mighty God

Matthew 16 ¹³ Now when Jesus came into the district of Caesarea Philippi, he asked his disciples, "Who do people say the Son of Man is?" ¹⁴And they said, "Some say John the Baptist, others say Elijah, and other Jeremiah or one of the prophets." ¹⁵He said to them, "But who do you say that I am?" ¹⁶ Simon Peter replied, "**You are the Christ, the Son of the living God.**" ¹⁷ And Jesus answered him, "Blessed are you, Simon Barjonah! For flesh and blood has not revealed this to you, but my Father who is in heaven." **Matthew 26** ⁶³ And the high priest said to him, "I adjure you by the living God, tell us if you are the Christ, the Son of God." ⁶⁴Jesus said to him, "You have said so. But I tell you, from now on you will see the son of Man seated at the right hand of Power and coming on the clouds of heaven." ⁶⁵Then the high priest tore his robes and said, "He has uttered blasphemy. What further witnesses do we need? You have now heard his blasphemy."

Many Jews today do not believe that Jesus is the Messiah because he did not bring peace for the Jews during his lifetime. He did not get rid of the Roman rule over Judea and Samaria and reestablish the Kingdom of Judah. The reason why he did not bring that type of peace is because he first must establish peace between God and man. If man is in rebellion towards God and don't love God, then why must God give man peace between one another? Man needs the forgiveness of his sin to be right with God and that can only be achieved through faith in the sacrifice Jesus made for sin on the cross. This has eternal value, because God promises eternal life to all his children. Peace between God and man is more important than peace between man and man. Jesus came to replace the animal sacrifices of the covenant of Moses that were just a temporary measure God put in place until the Messiah would come. If the Jews turn to Jesus and accept him as their Messiah, Lord and God then they will also be given peace in their own land. This will happen because God will help the Jews to convert their enemies to Christians through the preaching of the truth and the working of the Holy Spirit. This will end their ideology of animosity towards Jews, thereby Jesus will fulfil his role as the Prince of Peace. The ideology of Israel's enemies is all build upon age old lies. However, you cannot convince someone else that he is deceived by religious lies and convince him of the truth if you are not following that truth yourself. Listen to these wise words of Jesus and make peace with God through faith in his Son Jesus of Nazareth. This is the test God has given man to be saved from eternal judgement and receive eternal life instead.

Luke 6 ⁴¹*Why do you see the speck that is in your brother's eye, but do not notice the log that is in your own eye?* ⁴²*How can you say to your brother, "Brother, let me take out the speck that is in your eye," when you yourself do not see the log that is in your own eye? You hypocrite, first take the log out of your own eye, and then you will see clearly to take out the speck that is in your brother's eye.*

